

*Foremost*

**Model # : FI-MRTSR  
Fortunoff # : 55731-205**

## **MARTINIQUE SWIVEL ROCKER**

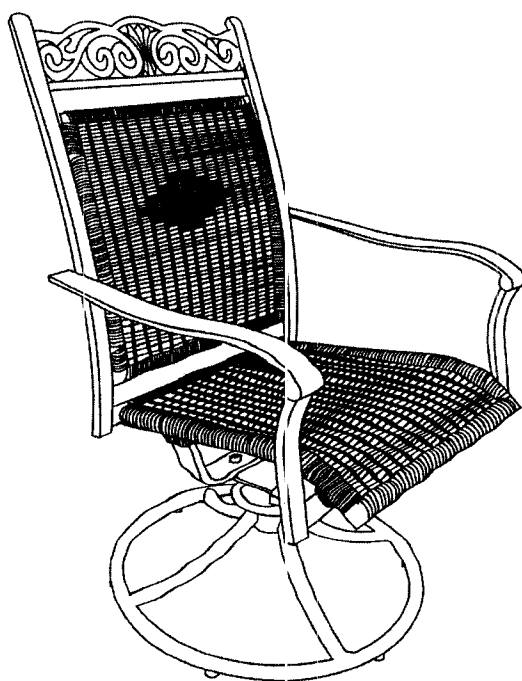

**Customer Service**

**E-Mail : [customerservice@fitnjo.com](mailto:customerservice@fitnjo.com)**

9:00a.m. – 5:30p.m. EST, M-F

**Toll Free 1-800-443-1410**

**Fax: (973) 428-6166**

**Website: [www.fitnjo.com](http://www.fitnjo.com)**

## WARNING!

*Chairs have a 250 lbs weight capacity.*

Please read instructions carefully and thoroughly before assembling. Check parts against the parts list to make sure you have all the parts needed for proper assembly. Familiarize yourself with the inventory of parts and the accompanying illustrations to ensure safe and proper assembly.

**Place chair on a carpeted flat surface to prevent scratching.**

## PARTS LIST

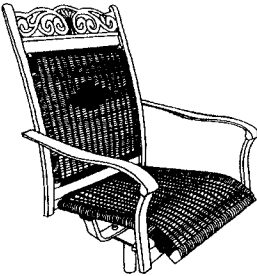
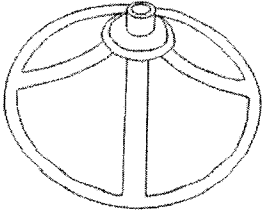
CSP#	PART	DESCRIPTION	PICTURE	QTY
PF-MRT.SR01-F05	A	CHAIR SEAT		2
PF-MRT.SR02-F05	B	CHAIR BASE		2

1

Place the chair base (B) on a flat surface and insert the chair seat (A) with stem into the chair base. Firmly push down to lock the chair seat (A) into the chair base (B).

(Figure 1)

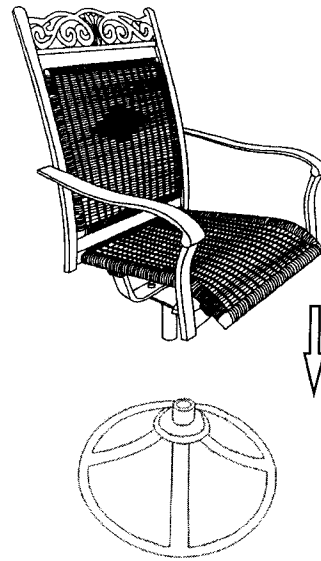

Figure 1

2

Repeat Step 1 to assemble the other chair. Your swivel rockers are now ready for your enjoyment.

(Figure 2)

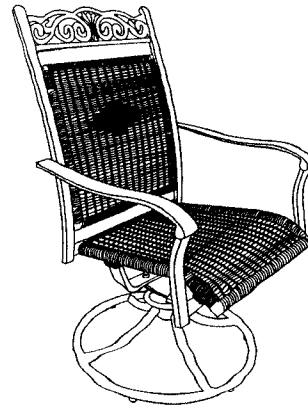

Figure 2

## CARE AND MAINTENANCE

All chairs and table frames should be washed with a mild soap and water solution. Rinse with clean water and dry with a soft towel. Do not use bleach or strong solvents to clean patio furniture. To maintain and protect the furniture, always cover it with an outdoor furniture cover or store in a safe area when not in use for long periods of time. Caution should be used when using oils, lotions and other chemicals such as chlorine or repeated exposure to extreme weather conditions (including heat), which may cause permanent discoloration to the fabric. Cushions should be taken in and stored in a dry area during rain. Should cushions get wet, please hang over chair frame to drip dry completely before using and storing. In areas where heavy snowfall occurs, do not allow snow to build-up on the table top, as breakage may occur due to weight limitations being exceeded.

## 3 YEAR LIMITED FRAME WARRANTY

**What is covered:** This product is covered under Foremost Groups, Inc. 3 Year Limited Warranty. To ensure your complete satisfaction, this warrants to the original purchaser that this furniture is free from structural defects as of the date of purchase and that it will, under normal use and proper care, remain so for 3 years after the date of purchase.

**What is not covered:** Freight and packing charges to and from our customer service center remain the customer's responsibility. Labor or material charges to remove or replace parts are not covered under this warranty. Any floor sample sales or clearance sales from the store are not covered by this warranty. Furniture used for commercial purposes, failures caused by improper care, unreasonable or abusive use, damage by modification or alteration; improper assembly, corrosion, rust, freeze damage, acts of God, fabric stains, mildew, ripping or fading, extreme heat, peeling, glass breakage, loss of use, inconvenience, or any other incidental damages. Proof of purchase (dated cash register receipts) and photographic images depicting damages are required for warranty claims

To obtain warranty service, please contact Foremost Groups Customer Relations Department at (800) 443-1410, between the hours of 9:00 am and 5:30 pm EST, Monday thru Friday or **fax your request to (973) 428-6166** or **email us at [customerservice@fitnjo.com](mailto:customerservice@fitnjo.com)** or visit our **website at [www.fitnjo.com](http://www.fitnjo.com)**.